

ITU IMT-2000 Seminar
Warsaw, October 2001

ON OPTIMIZATION OF 3G CELLULAR SYSTEMS DEPLOYMENT

Prof.dr Milica Pejanovic
University of Montenegro, Podgorica, Yugoslavia
E-mail: milica@cg.ac.yu

EVOLUTION OF CELLULAR SYSTEMS

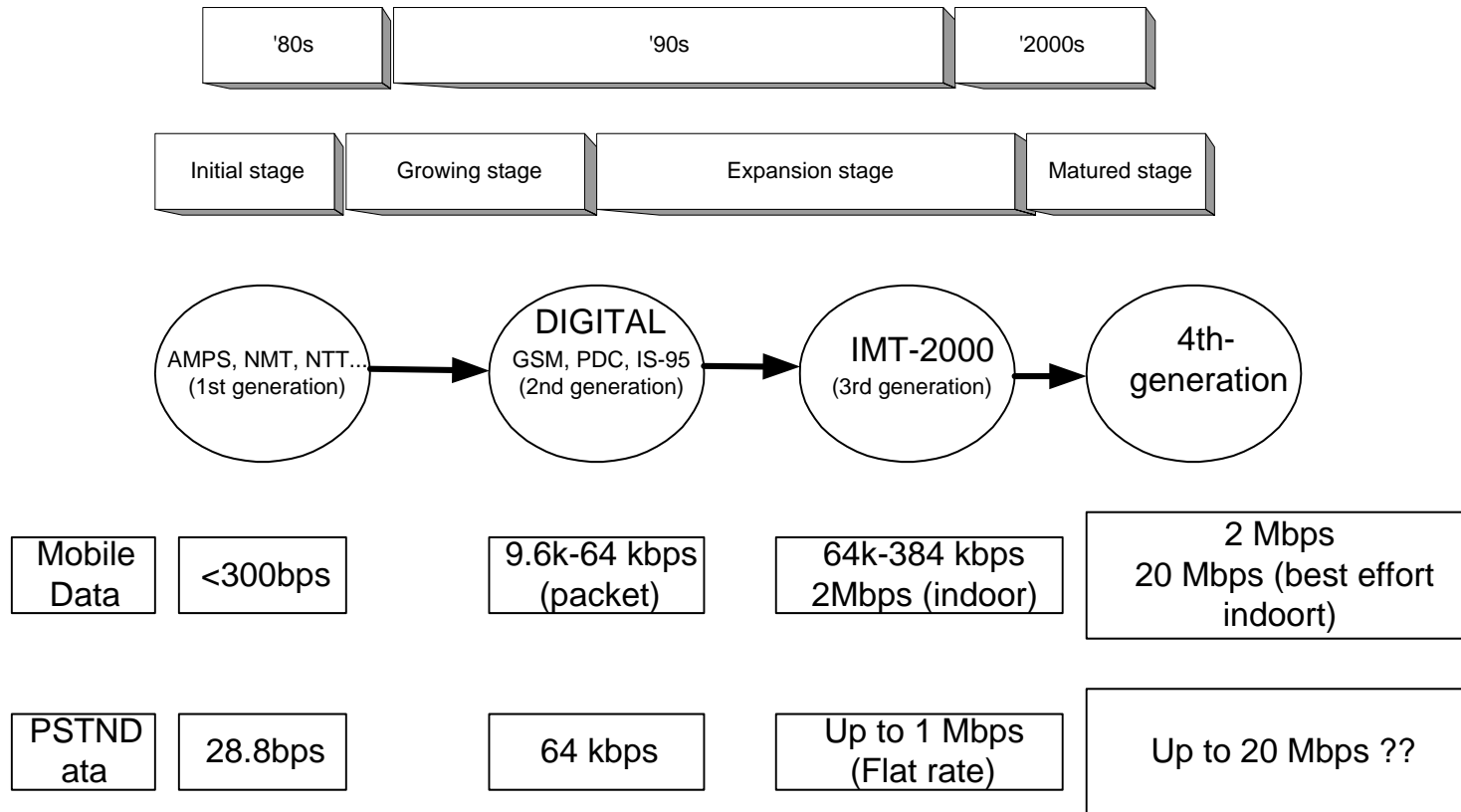

WORLDWIDE DISTRIBUTION OF CELLULAR STANDARDS

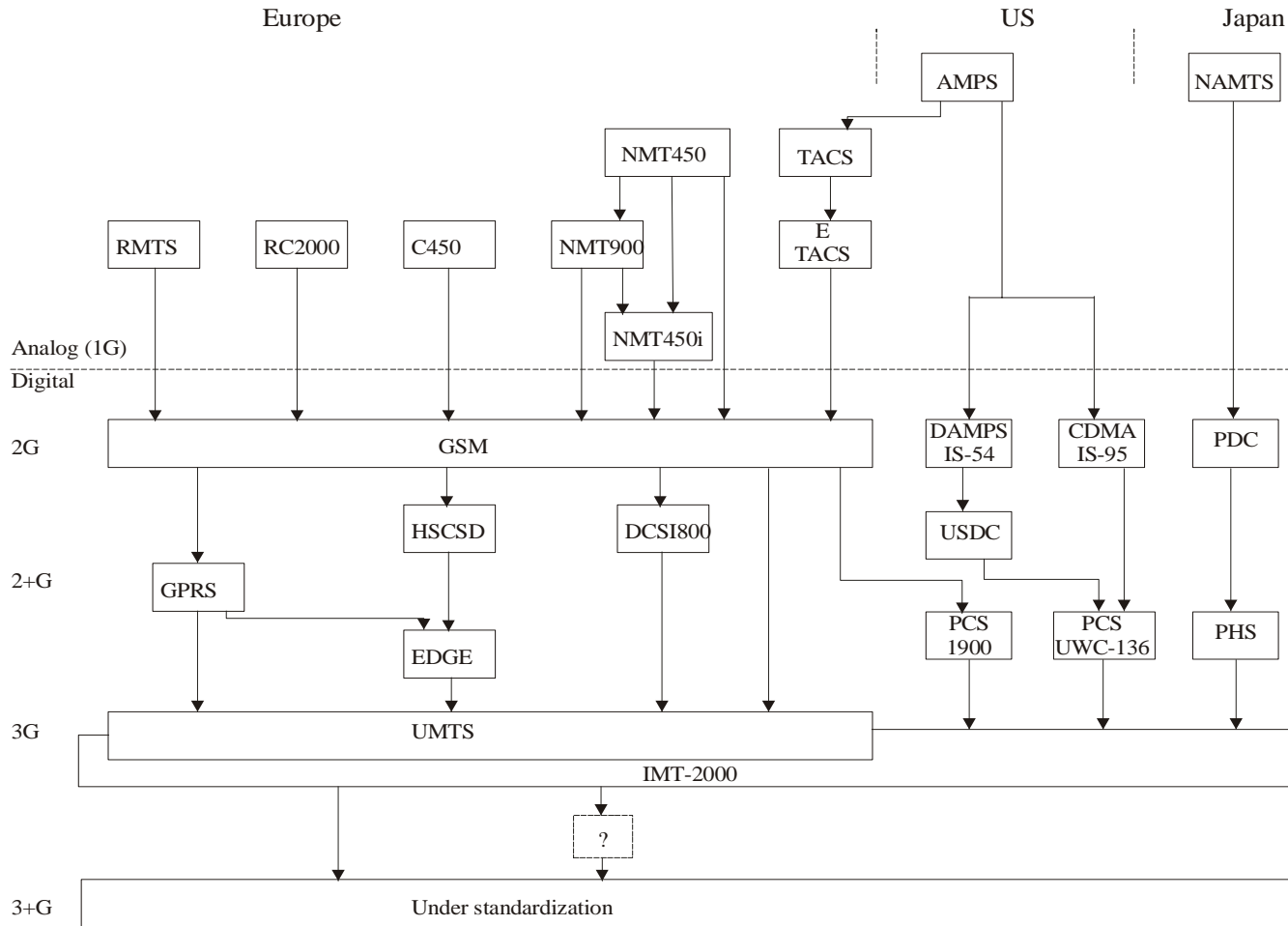

DEVELOPMENT TRENDS IN WIRELESS STANDARDS

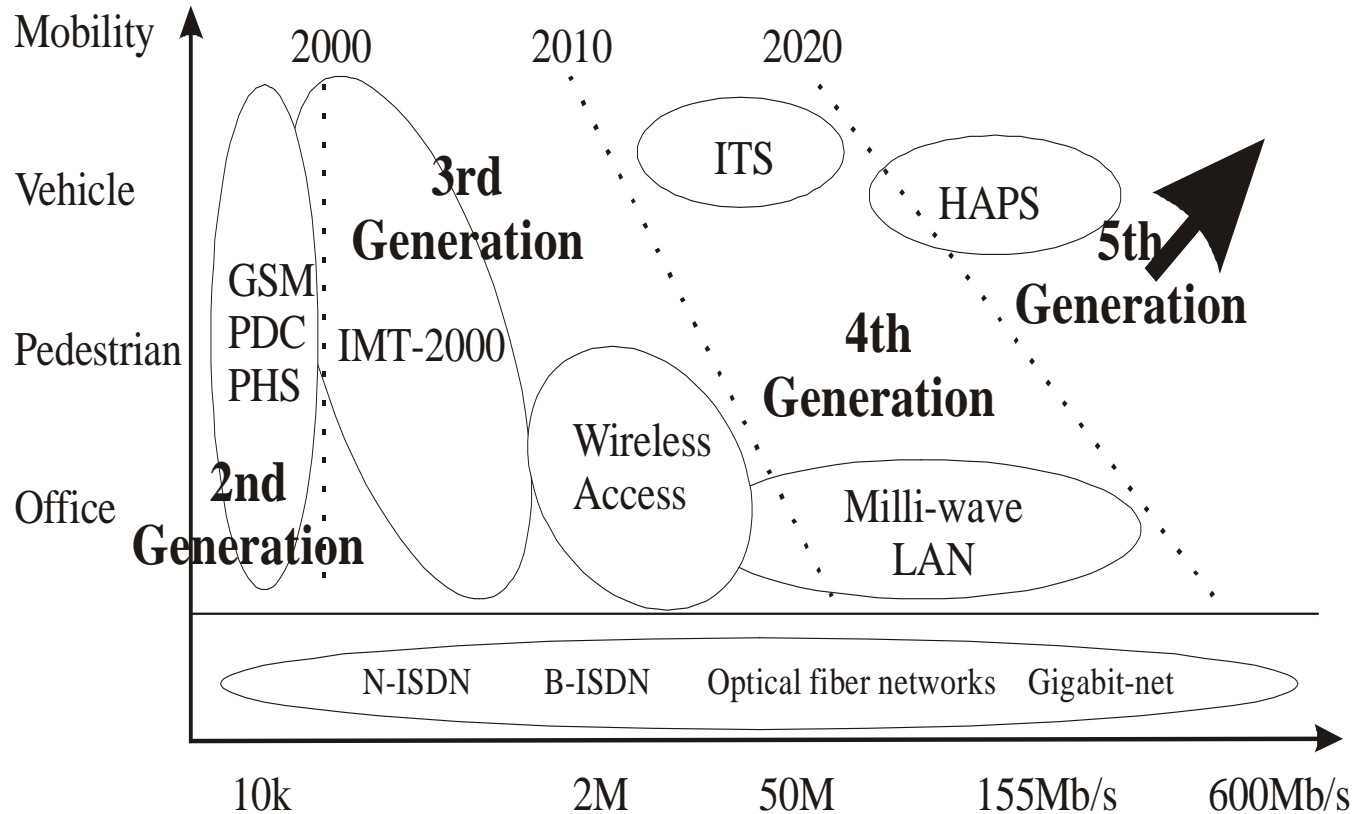

TARGETED FEATURES OF 3G NETWORKS

3G networks should provide access, by means of one or more radio links, to a wide range of telecommunications services supported by the fixed telecommunication networks (e.g. PSTN/ISDN/IP), and to other services which are specific to mobile users.

Key features of such wireless cellular systems should be:

- high degree of commonality of design world-wide;
- compatibility of services within 3G standards and with the fixed networks;
- high quality;
- small terminal for world-wide use;
- world-wide roaming capability;
- capability for multimedia applications, and a wide range of services and terminals;
- support of a limited number of different radio interface technologies within the 3G family.

COMPARISON OF 2G AND 3G CELLULAR SYSTEMS

System Aspects	Existing 2 G Mobile Systems	New 3 G IMT-2000 Systems
Use of digital technology	Already used for modulation, speech and channel coding as well as implementation and control of data channels	Increased use of digital technologies
Commonality between different operating environments	Each systems is primarily optimised for its specific operating environment	Optimisation of radio interfaces for multiple operating environments such as vehicular, pedestrian, intro-office, fixed wireless access and satellite, via a single flexible or scalable radio interface.
Frequency bands	Operate in frequency bands ranging from 800 MHz to 1.9 GHz, depending on the country	Use a common global frequency band
Data services	Limited to data rates below 115 kb/s (WAP-GRPS-SMS)	Transmission speeds up to 2 Mb/s
Roaming	Generally limited to specific regions, Handsets not compatible between different systems	Global frequency coordination and ITU standards will provide true global roaming and equipment compatibility
Technology	Spectrum efficiency, cost and flexibility limited by technology in use at time of system design	Spectrum efficiency, flexibility and overall costs all significantly improved.
Radio interfaces	TDMA, CDMA	W-CDMA
Data speed	9.6 kb/s with evolution up to 171.2 kb/s (2.5 G)	144 kb/s – 2 Mb/s

LAYERED ARCHITECTURE OF 3G NETWORKS

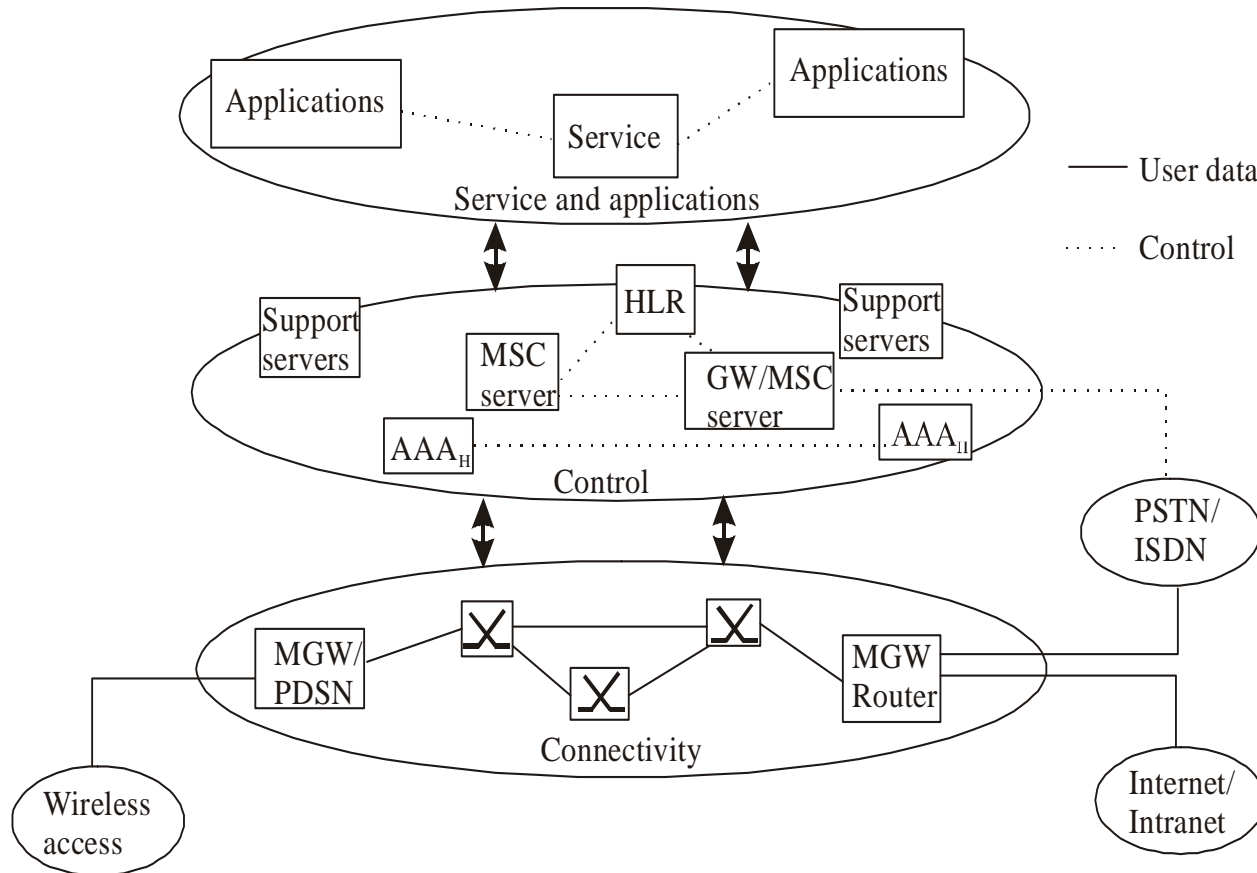

OVERVIEW OF 3G STANDARDIZATION BODIES

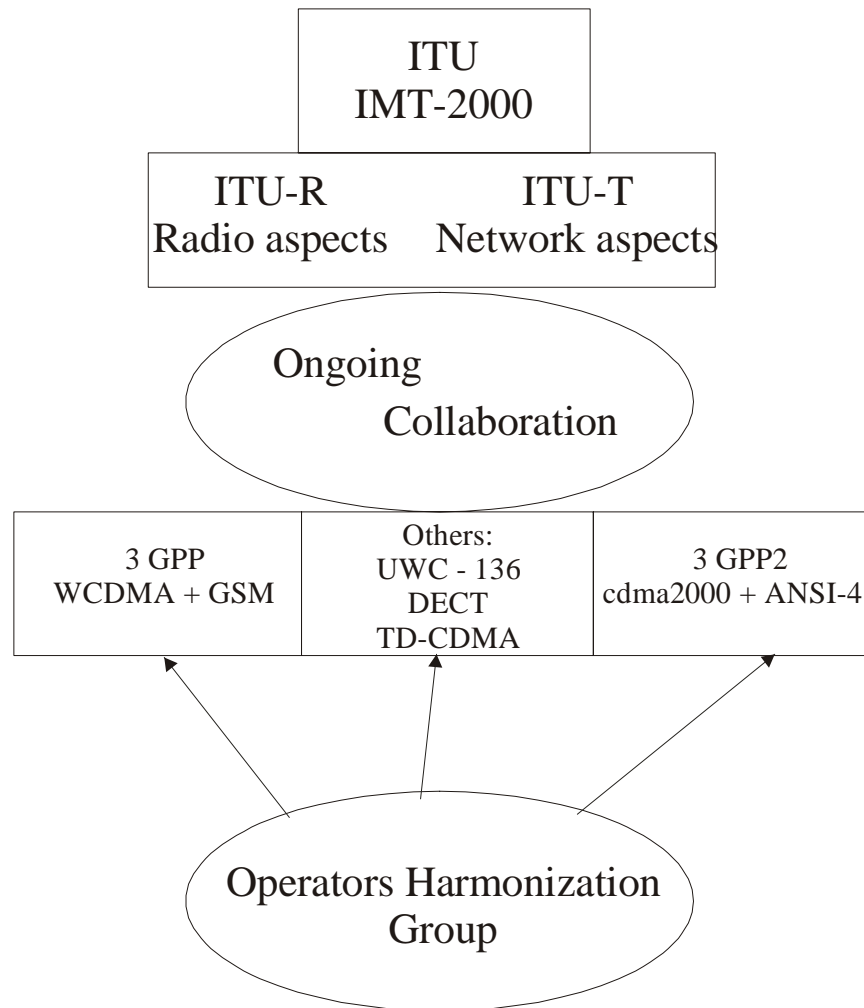

OPERATORS HARMONIZATION AGREEMENT

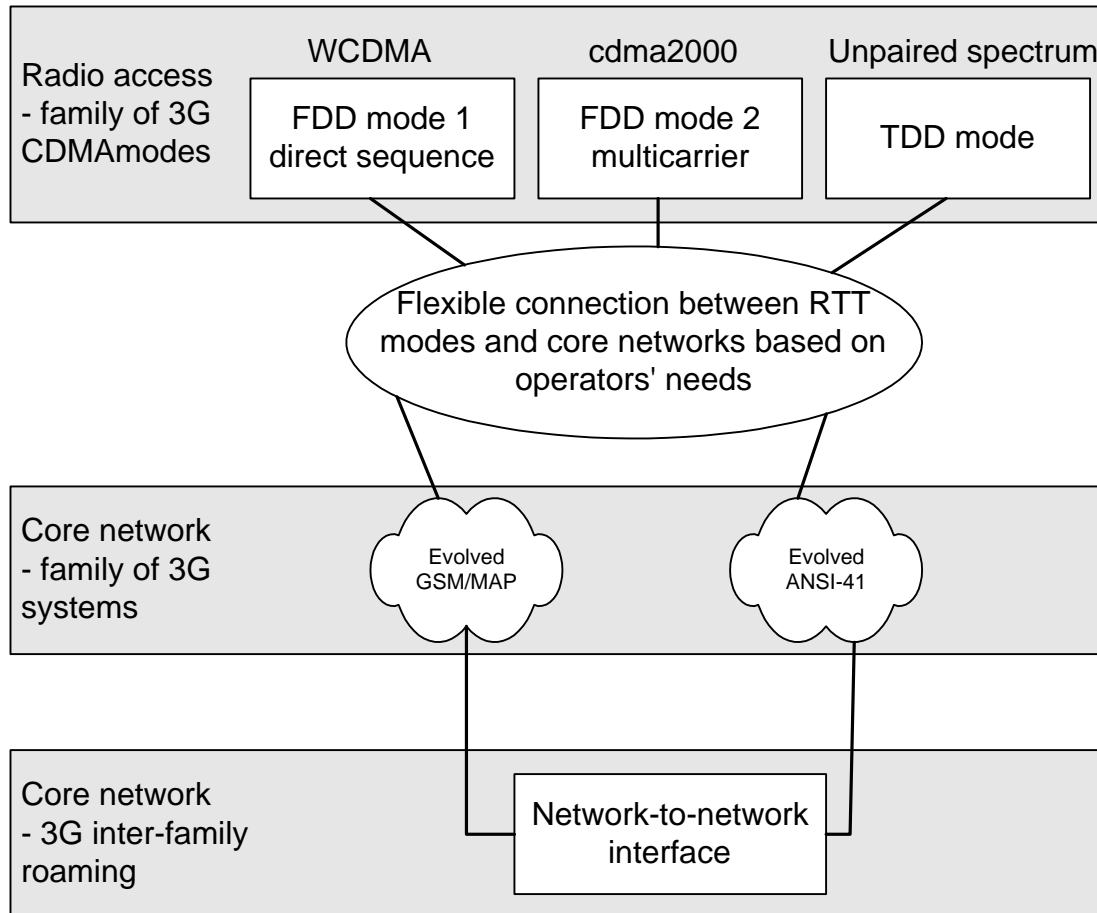

3G RADIO INTERFACE STANDARDIZATION

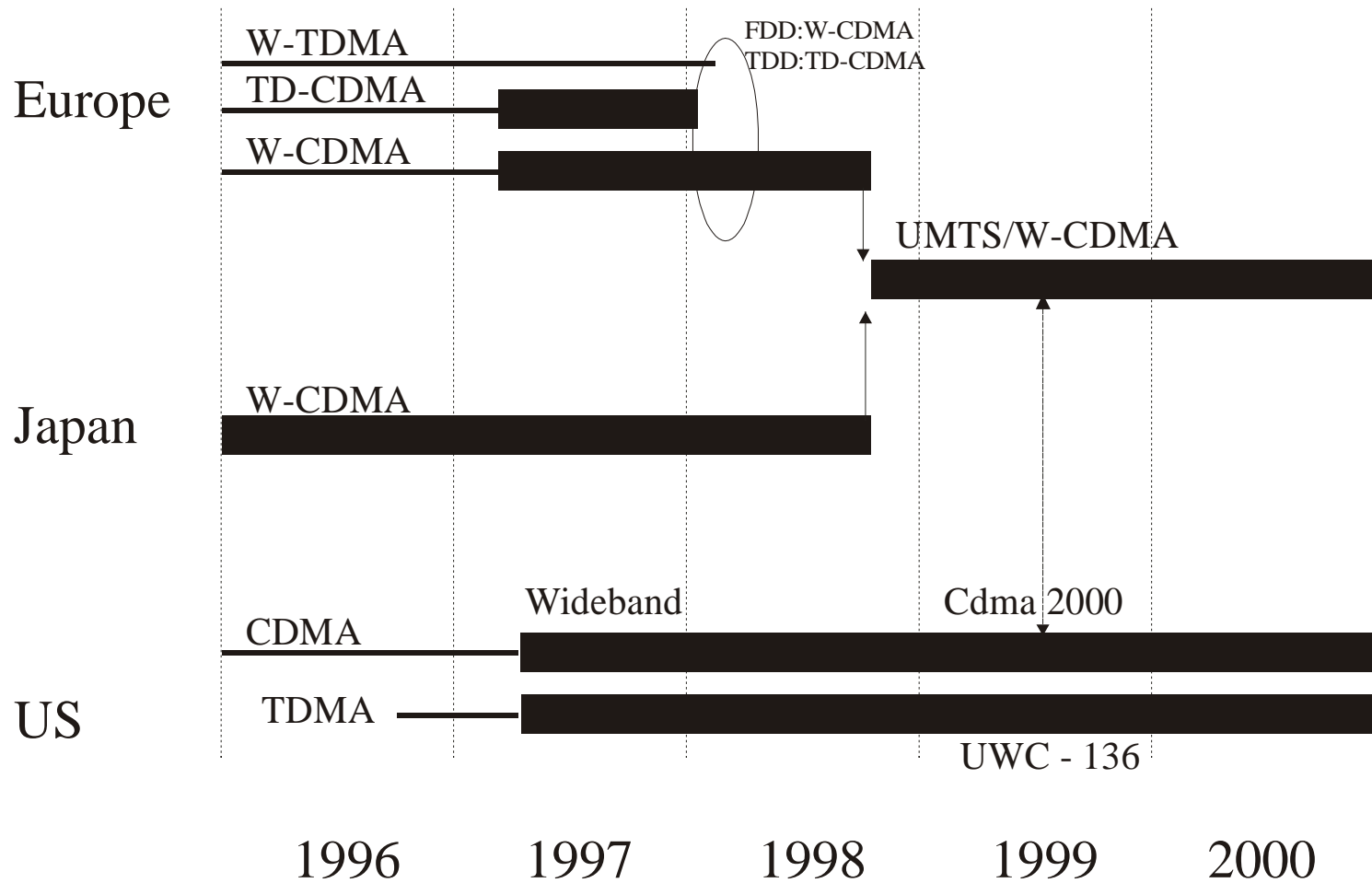

IMT-2000 TERRESTRIAL RADIO INTERFACES

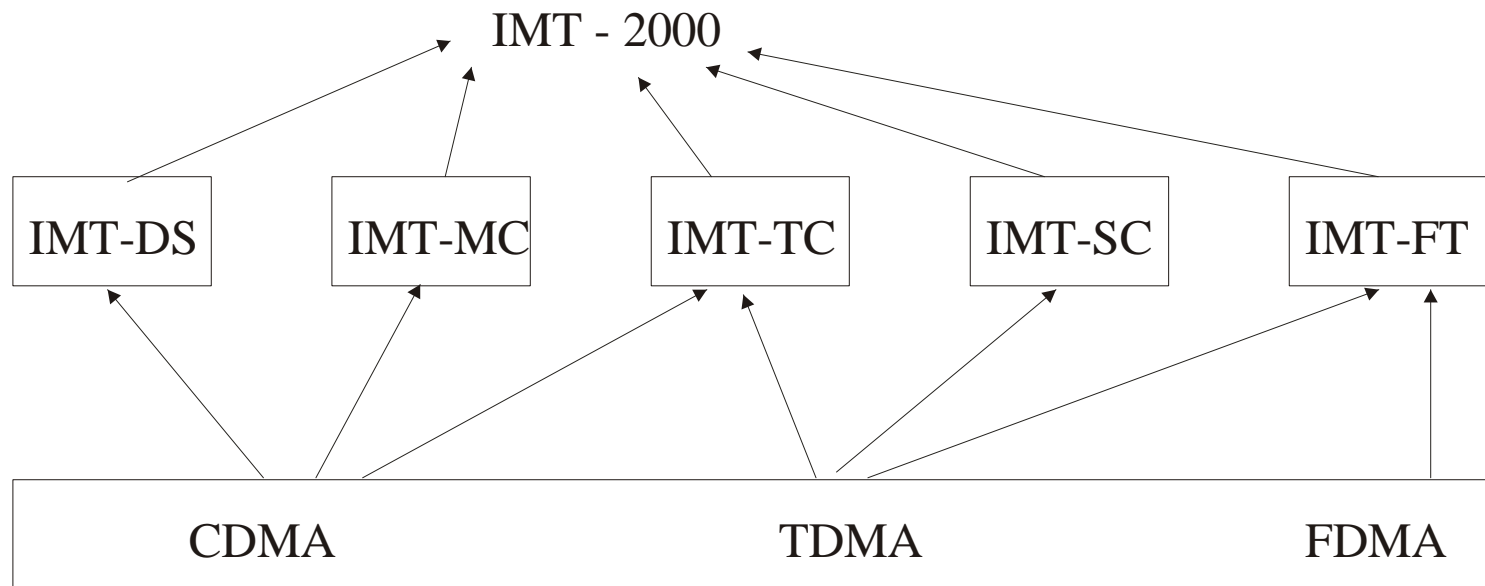

IMT-DS (Direct Spread)=W-CDMA (FDD)

IMT-MC (Multi Carrier)=cdma 2000

IMT-TC (Time-Code)=UMTS TDD, TD-SCDMA

IMT-SC (Single Carrier)=UWC-136

IMT-FT (Frequency Time)=DECT

MIGRATION SCENARIOS TOWARDS 3G NETWORKS

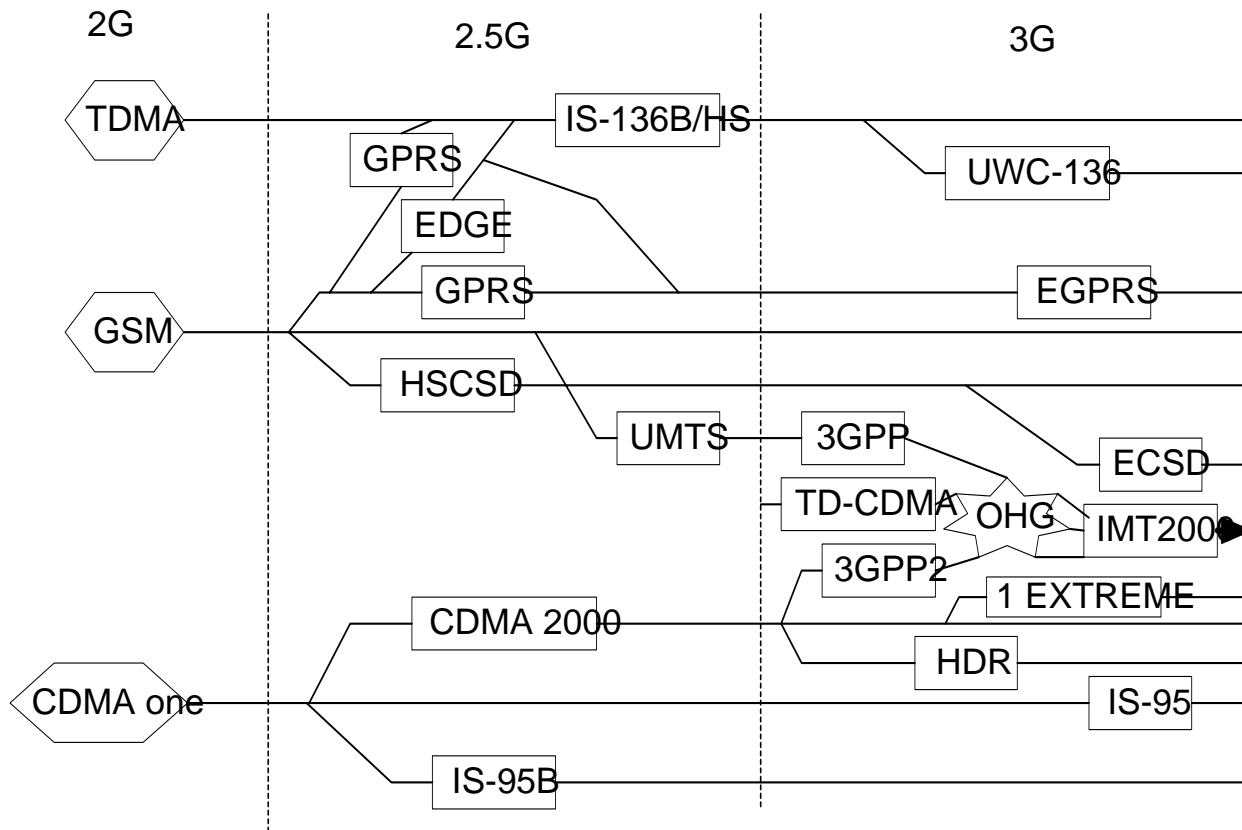

EVOLUTION OF THE IS-95 AIR STANDARD

- IS-95-A
 - Standardized by Telecommunications Industry Association (TIA) in July 1993. Networks utilizing IS-95 CDMA air interface and ANSI-41 network protocol are branded as cdmaOne networks. IS-95 networks use one or more 1.25MHz carriers, operate on 800 and 1900MHz bands. Data rates of up to 14.4kb/s and soft handoffs are supported.
- IS-95-B
 - Improvements for hard-handoff algorithms in multicarrier environments and in parameters that affect the control of soft handoffs. Higher data rates of up to 115kb/s can be supported by bundling up to eight 14.4 or 9.6 kb/s data channels.
- Cdma2000
 - Developed to support 3G services. This standard is divided into two phases:
 - **Cdma2000 1X** – 1X stands for standard carrier (1.25MHz) at air interface. It delivers twice the voice capacity of cdmaOne with average data rates of 144kb/s.
 - **Cdma2000 3X** – 3X stands to signify 3x1.25MHz with data rates of up to 2Mb/s

TIMELINE FOR EVOLVING CDMA TO 3G CAPABILITIES

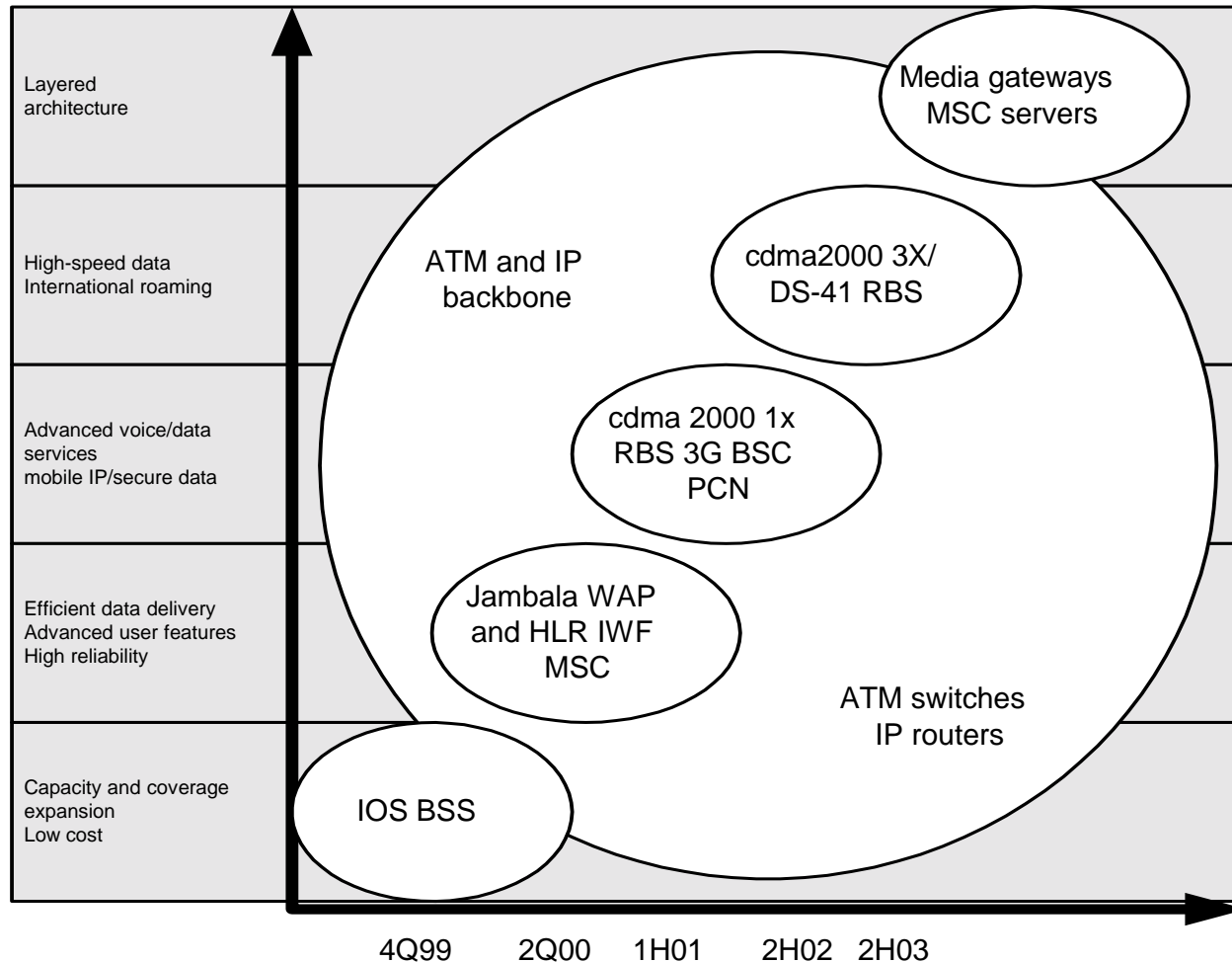

EVOLUTION OF THE TDMA AIR STANDARD

- TDMA (TIA/EIA-136)
 - This standard includes EIA-553 and IS-54 systems
- IS-136HS
 - For satisfying requirements for IMT-2000, the Universal Wireless Communication Consortium (UWCC) proposed the 136 High-Speed (136HS) radio interface.
- EDGE (Enhanced Data Rates for GSM Evolution)
 - In January 1998, UWCC adopted EDGE as outdoor component of 136HS. EDGE was thus included in UWC-136 IMT-2000 proposal. It provides 384 kb/s data services and comprises two phases:
 - Phase I emphasizes enhanced GPRS (EGPRS) and enhanced circuit-switched data (ECSD)
 - Phase II is defined to include improvements for multimedia and real-time support

Model for an EGPRS/136 network integrated into a TIA/EIA-136 circuit-switched network through an SGSN gateway MSC/VLR

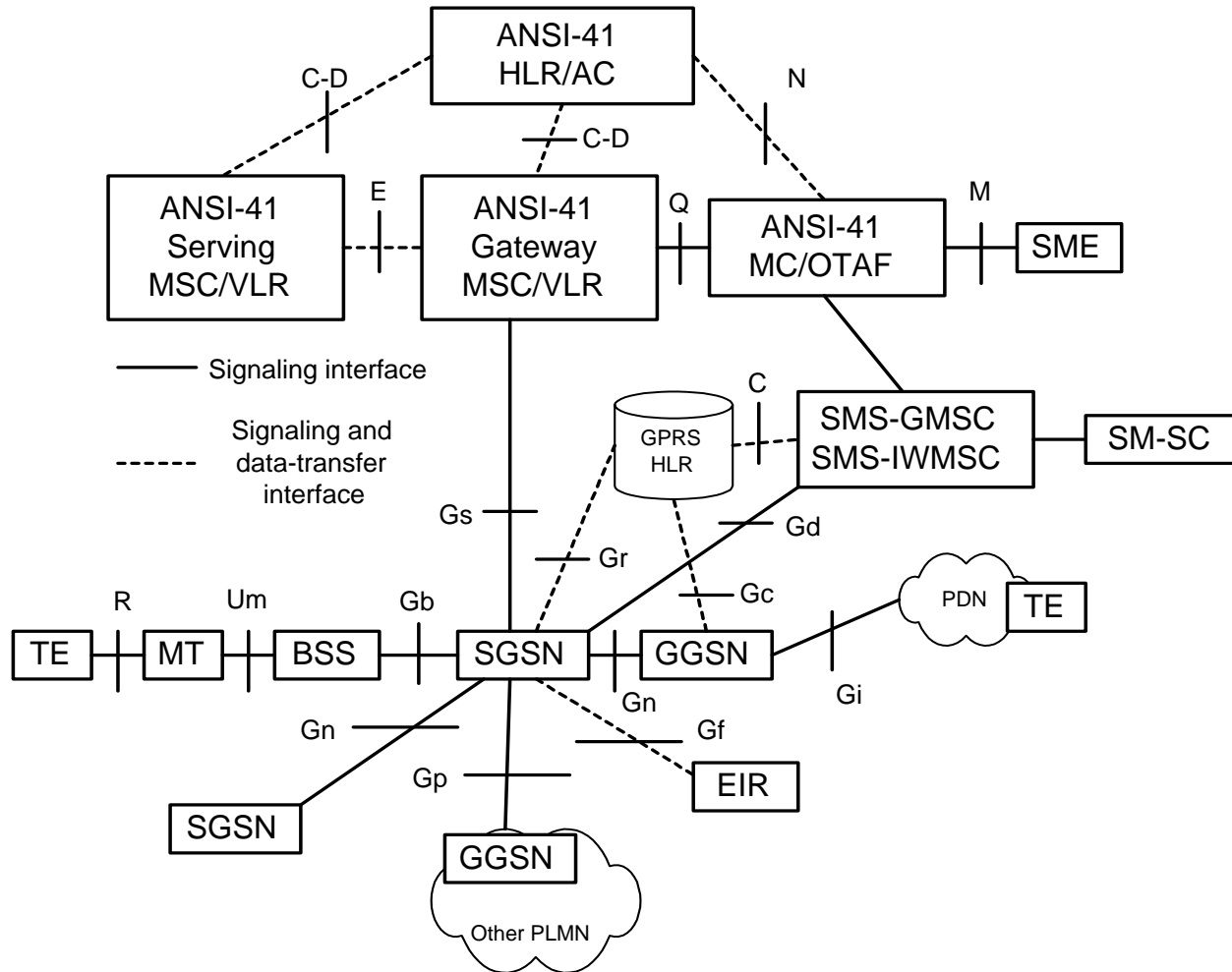

EVOLUTION OF THE GSM AIR STANDARD

- **GSM (Global System for Mobile Communications)**
- **GSM + standard**
 - Enables packet mode extensions to GSM using the same air interface but with a new physical channel. It could be done through the following three possibilities:
 - **HSCSD** (High Speed Circuit Switched Data Service)
 - **GPRS** (General Packet Radio Service) (and EGPRS)
 - **EDGE**
- **UMTS (Universal Mobile Telecommunications System)**
 - European version of IMT-2000 which is composed of a core network (CN) connected with interface (I_{u}) to the radio access network called the UMTS Terrestrial Radio Access Network (UTRAN). This standard supports W-CDMA in two versions:FDD (frequency-division duplex) and TDD (time-division duplex).

GPRS ARCHITECTURE

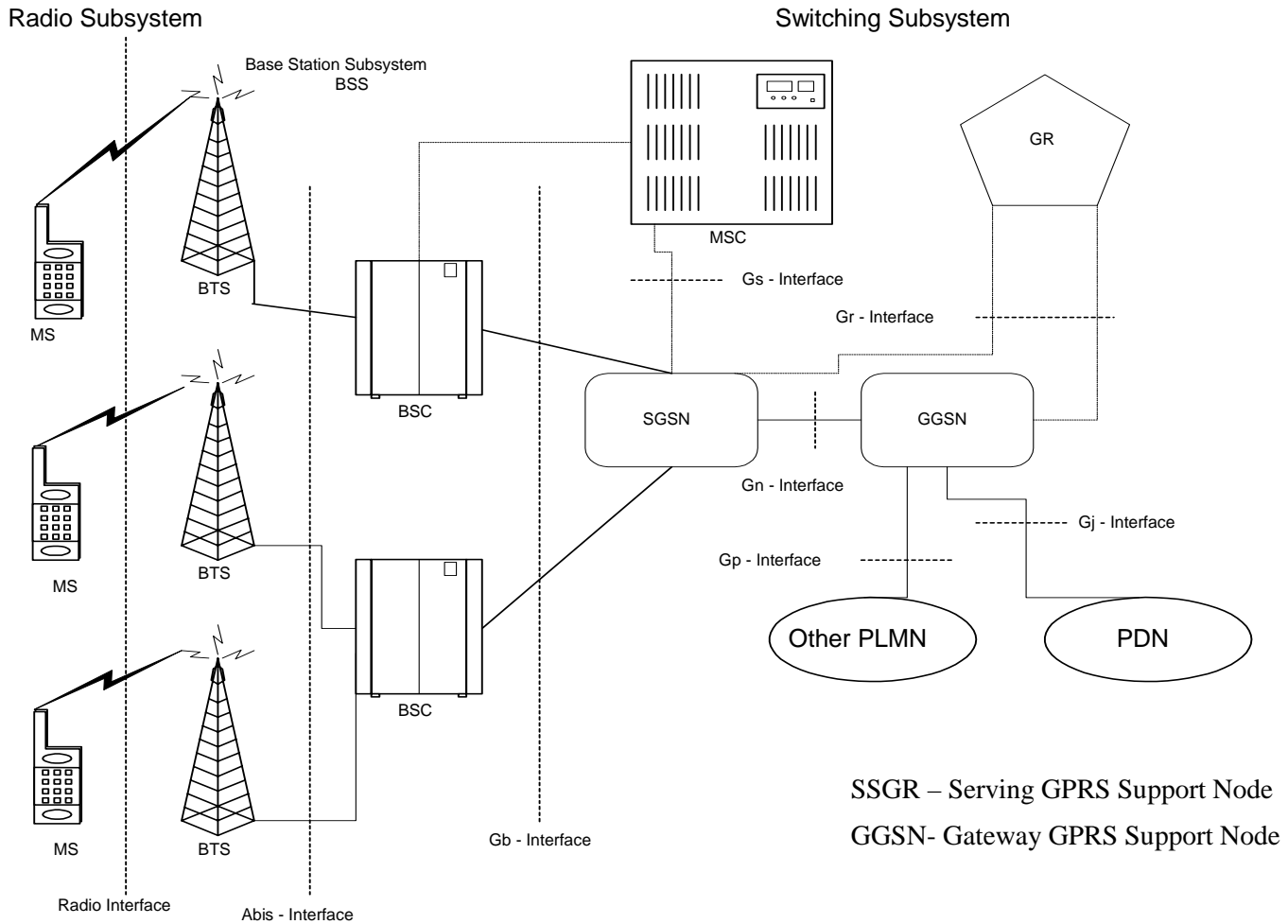

COMPARISON OF GSM + STANDARDS

Name	Max. Bandwidth (kbit/s)	Circuit-switched packet-switched	HW-Upgrade Required?	Typical Application Environment	Pro's and Con's
HSCSD	57.6	CS	No	Rural and urban, mobile and stationary	+ Available now - Expensive for subscriber
GPRS	115	PS	Yes	Mostly urban, mobile and stationary	++ Being online permanently ++ Charging based on volume
EDGE	384	PS+CS	Extensive	Urban, mostly stationary	++ Top speed -- Extensive HW-upgrade

UMTS (3GPP) ARCHITECTURE RELEASE '99 (R3)

This release supports WCDMA access and ATM-based transport

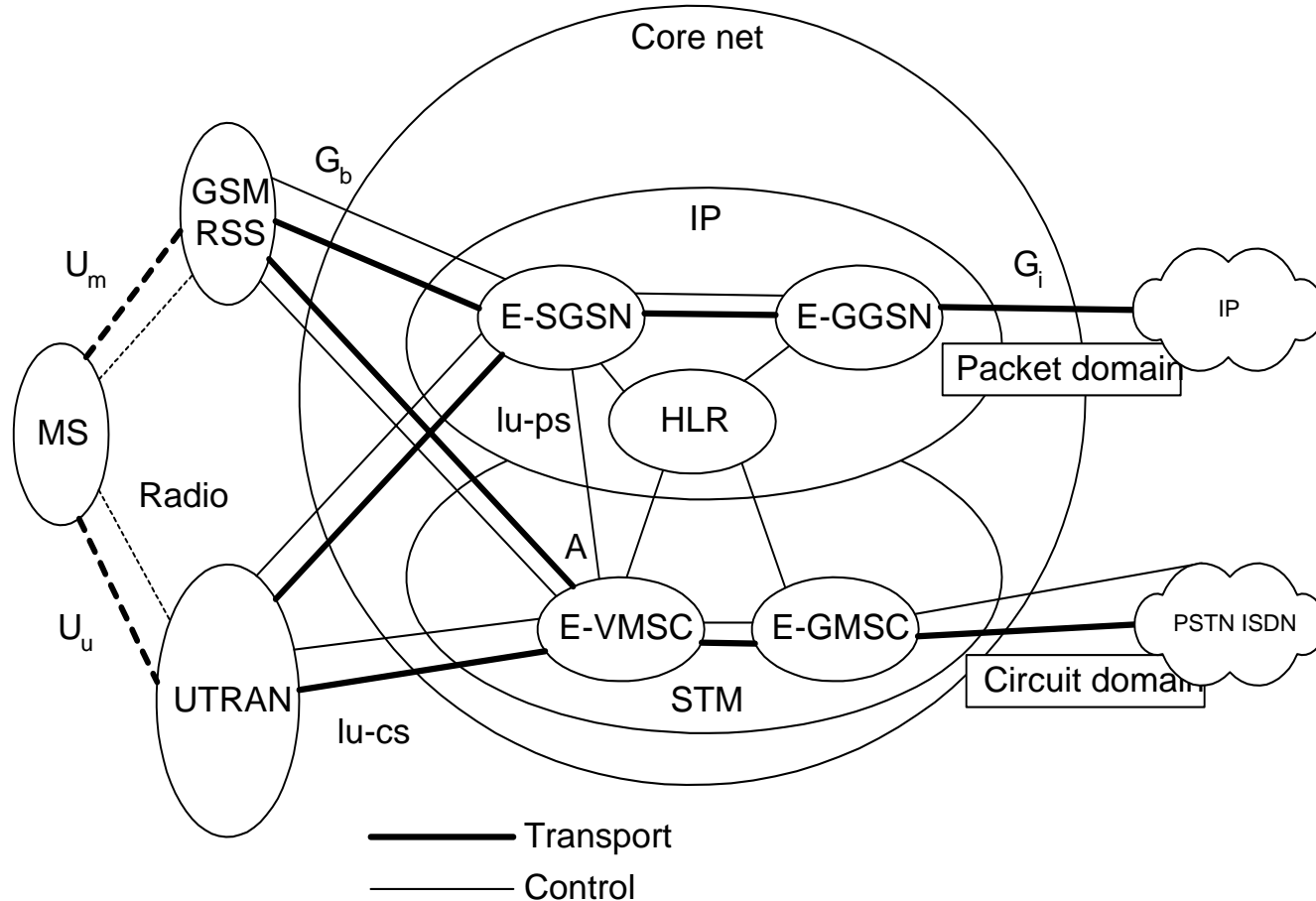

UTRAN ARCHITECTURE

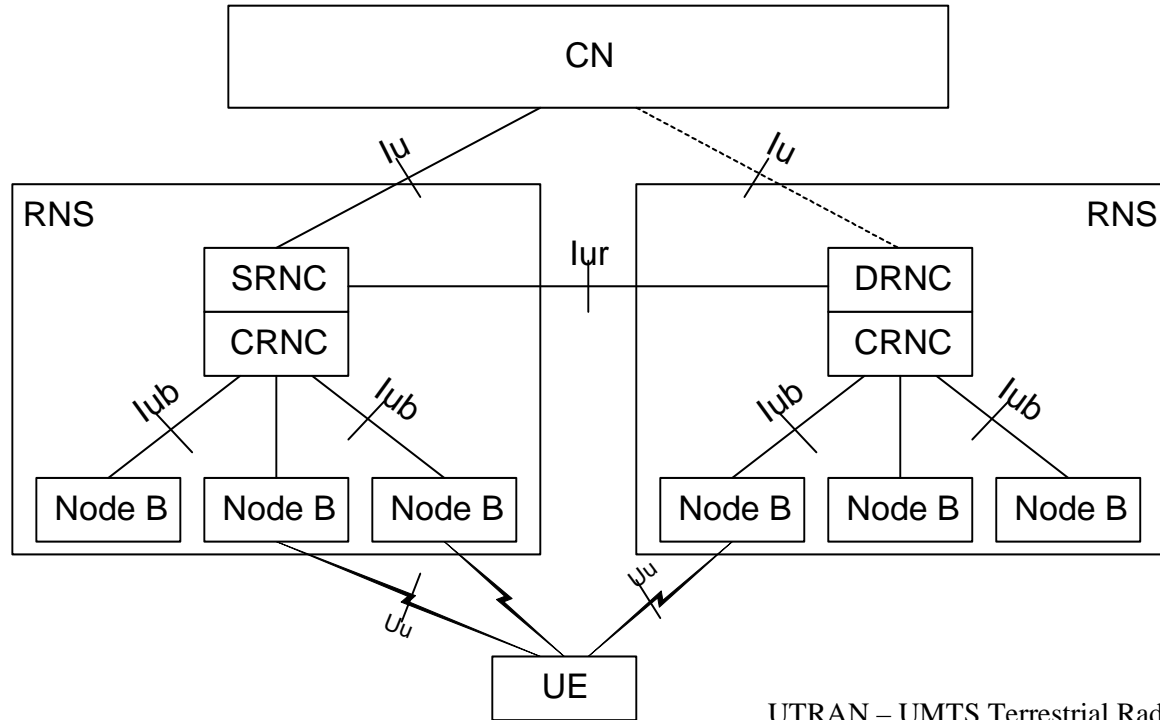

UTRAN – UMTS Terrestrial Radio Access Network

RNS – Radio Network Subsystems

RNC- Radio Network Controller

UMTS R3 is composed of the UTRAN attached to two separate core network domains:

- Circuit switched domain based on enhanced GSM MSCs consists of the following network elements:
 - 2G/3G mobile-services switching center including the VLR functionality
 - HLR with AC (Authentication Center) functionality

- Packet switched domain built on enhanced GPRS support nodes consists of:
 - 2G/3G serving GPRS support node with subscriber location register (SGR) functionality
 - Gateway GPRS support node (GGSN)
 - Border gateway

UMTS (3GPP) ARCHITECTURE RELEASE 00

It is split into R4 (00) and R5(00+) defining two RAN technologies:
 GPRS/EDGE radio access network (GERAN) and W-CDMA as in R3

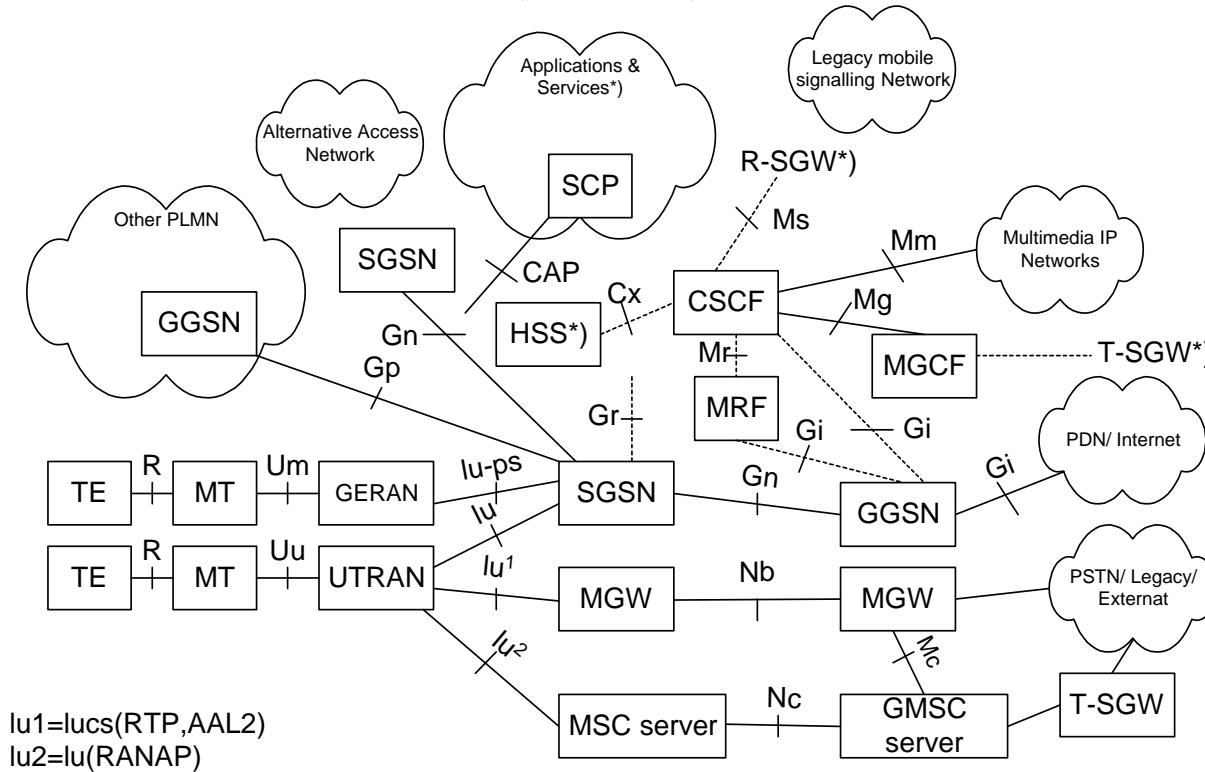

lu₁=lu(cs(RTP,AAL2))
 lu₂=lu(RANAP)

----- Signalling interface

————— Signalling and Data Transfer interface

*) those elements are duplicated for figure layout purpose only,
 they belong to the same logical element in the reference model

EVOLUTION PATHS FOR MIGRATION TO UMTS R5

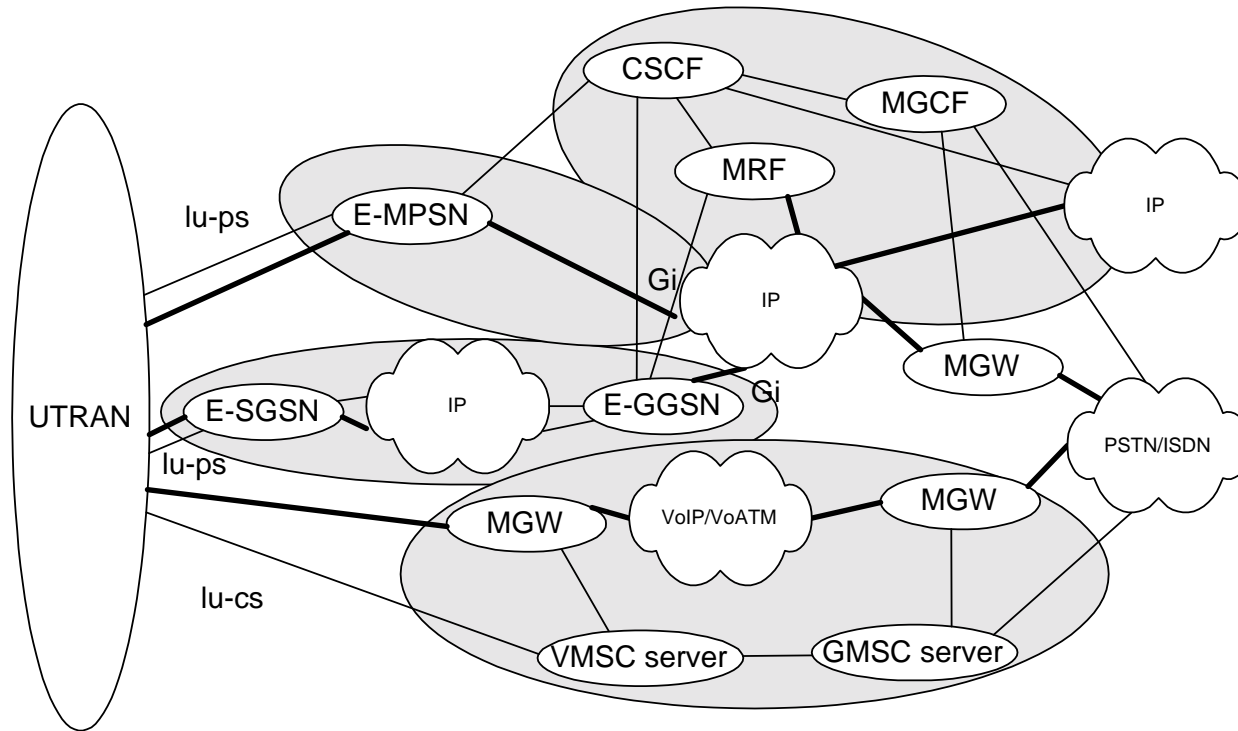

R5 introduces All-IP environment including:

- Transport: utilization of the IP transport and connectivity with QoS throughout the network
- End-user services: with Session Initiation Protocol (SIP) possibilities to offer wide range of totally new services

GSM MIGRATION PHASES

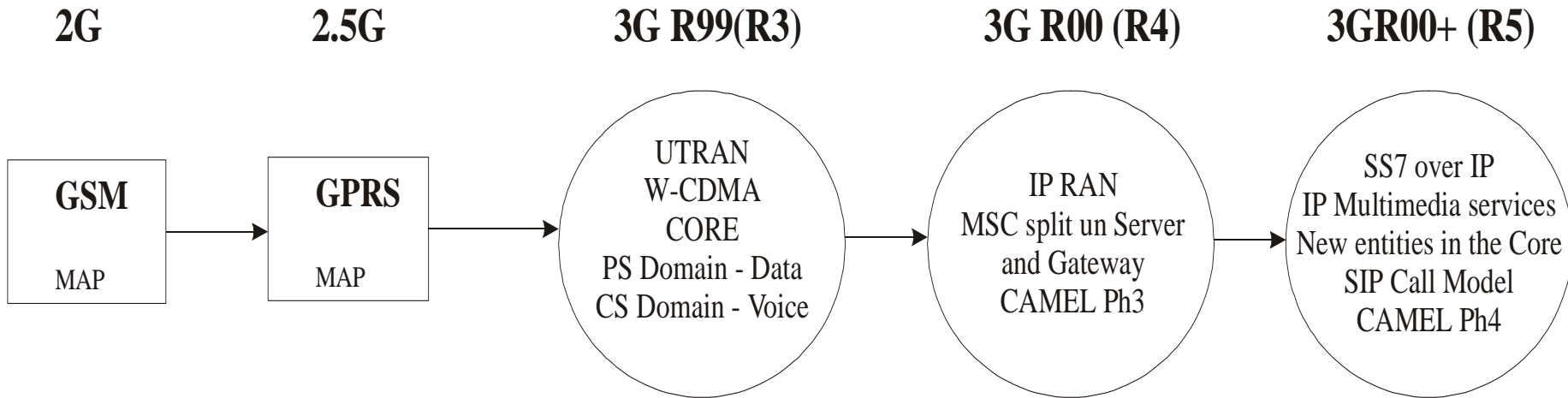

- Phase 1 - GSM CS Voice and Data
- Phase 2 - GPRS Overlay Network
- Phase 3 - UMTS R99
- Phase 4 - All IP UMTS R00
- Phase 5 - IP Multi-media (IM)

MIGRATION OF GSM TO UMTS

	GSM Phase 2	GSM Phase 2+	UMTS
Multiple access	FDMA/TDMA	FDMA/TDMA	TDMA/CDMA
Max. bit rate	9.6 kbit/s	64 kb/s; 115kb/s	384 kb/s; 2 Mb/s
Speech quality	Full rate (FR)	Enhanced full rate (EFR), transcoder free operation (TFO)	Adaptive multirate (AMR)
Capacity	900 MHz	Tri-band (900, 1800, 1900 MHz)	2000MHz, spectrum efficiency
Roaming	International roaming	Global roaming	Seamless global roaming in multiradio environments and applications areas
Security	Authentication, encryption	Fraud information gathering, SS7 security, lawful interception (LI)	Enhanced authentication and user identity confidentiality, network domain security
Bearers	Circuit-switched bearers	64 kbit/s circuit bearer, packet bearers by General Packet Radio Service (GPRS)	Circuit- and packet-switched bearers, real-time packet bearer
Services	Speech and low-speed circuit-switched data, supplementary services, short message service	Service customization, service portability, value-added services, mobile Internet access, and Web-like information service	Full Internet capability, speech, data, multimedia, virtual home environment (VHE)

DEPLOYMENT STRATEGIES FOR 3G SYSTEMS

When choosing an adequate approach in 3G systems deployment, the following elements have to be considered:

- **network type (private-public),**
- **coverage (local-global),**
- **mobility (low-high),**
- **data traffic (low-high),**
- **types of services (basic-multimedia).**

Thus, two approaches may be identified:

Scenario 1 – innovative, applied through implementation of the completely new 3G network

Scenario 2 – evolutionary, applied through migration (upgrade) of already existing 2G or 2G+ network

DEPLOYMENT SCENARIO No.1

In this type of scenario the following versions may appear:

➤ **SCENARIO No.1(a): All-round**

3G network is implemented where no 2G network exists both in terms of deployment area and the transmission rate

➤ **SCENARIO No.1(b): Complement**

3G network is implemented in the region with already existing 2G network(s) in a way that it could be:

- **Area-complement** – 3G covers the whole range of the transmission rate and is located in the position not covered by 2G networks in the terms of the deployment area
- **Rate-complement** – 3G covers the whole range of the deployment area and is located in the position not covered by 2G networks in terms of the transmission rate.

COMPARISON OF SCENARIOS No.1(a) AND No.1(b)

	All-round-type scenario	Complement-type scenarios
Transmission bit rate	From lower to higher rates	Higher rate
Mobility	From static to cellular mobility	Cellular mobility
Deployment Area	From pico to macro cells	Micro and macro cells
Network interface	If necessary	Indispensable
System roaming	If necessary	Indispensable
Radio interface	Single	Multiple
Mobile terminal mode	Single	Multiple
Security	Whole system	Core network
Billing/charging	Unified system	Multiple systems
Core network	Customized	Transparent
Service provider	Single	Multiple
2G, 3G and other mobile systems	Overlap	Complement

DEPLOYMENT SCENARIO No.2

There are two possible ways for mobile operators to migrate from 2G (2G+) to 3G:

- **Scenario No.2(a):** Existing 2G or 2G+ core network could be upgraded for 3G use. In this case 2G and 3G networks share the same core infrastructure.
- **Scenario No.2(b):** Independent 3G core network could be implemented completely independent from the existing 2G core infrastructure.

SCENARIO No.2 (a) – COMMON CORE NETWORK FOR 2G AND 3G

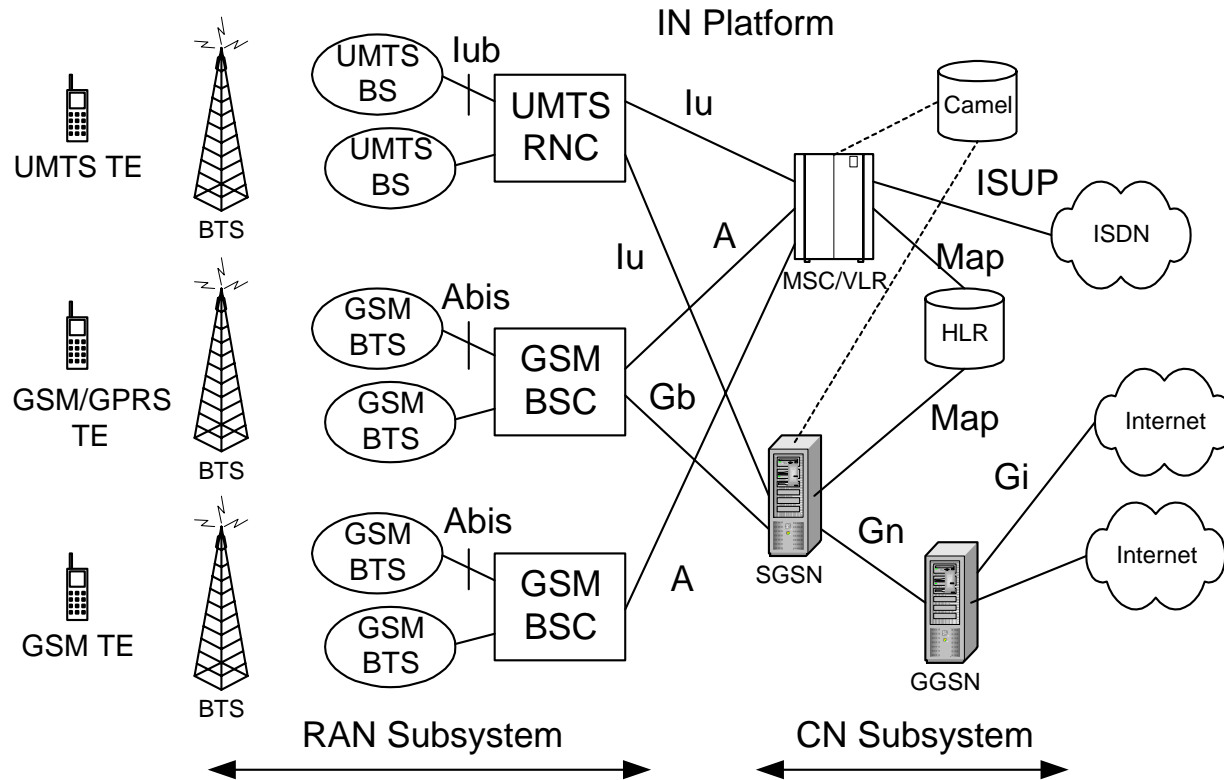

SCENARIO No.2 (b) – INDEPENDENT 2G AND 3G CORE NETWORKS

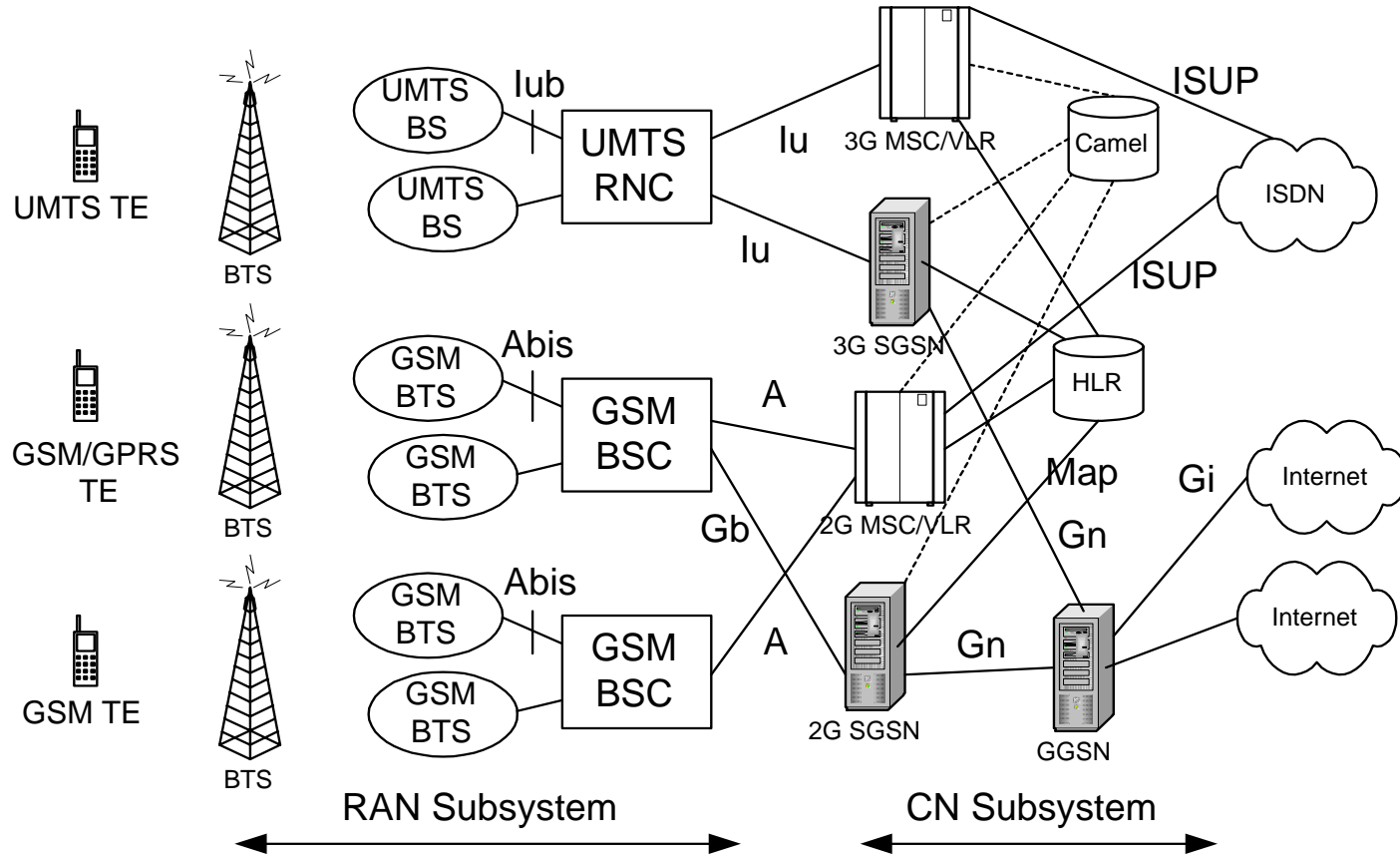

IMPACTS OF SCENARIOS No.2 ON EXISTING 2G NETWORKS

- **SCENARIO No.2(a):**
 - Re-dimension of the existing core network to be able to support 3G broadband services
 - Optimize transmission network for a suitable traffic mix
 - Network management system

- **SCENARIO No.2(b):**
 - 2G and 3G networks have minimum impact on each other

OPTIMAL SCENARIO No.2 IMPLEMENTATION

Voice (Existing GSM Network)

Data

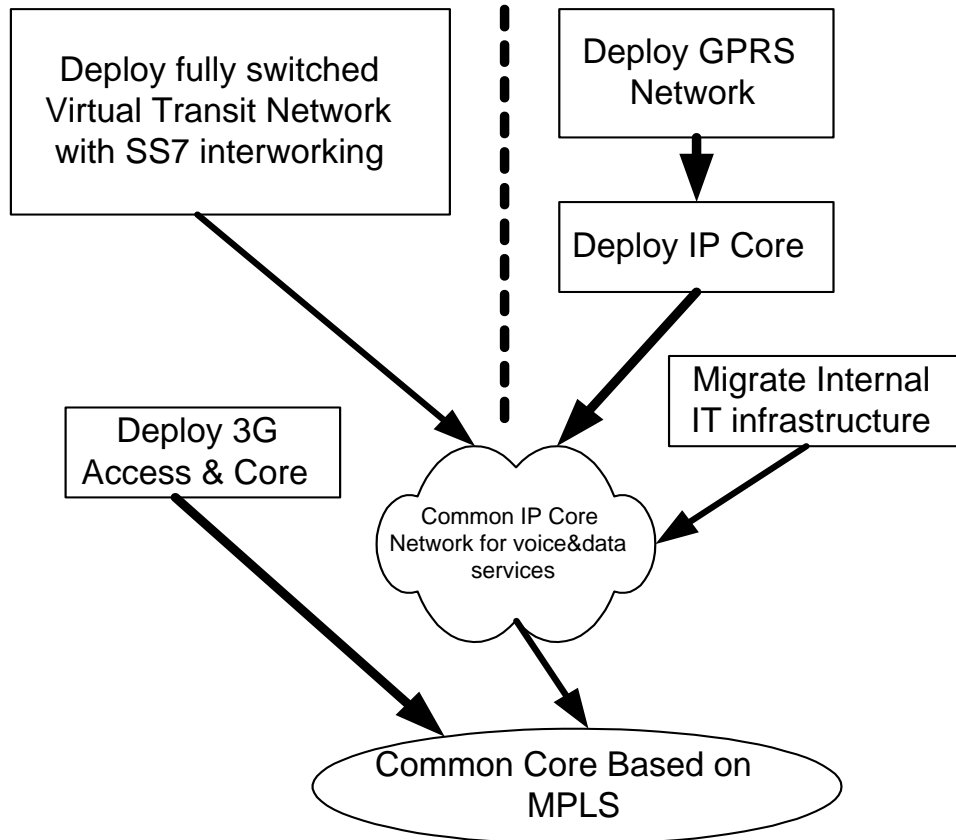

Abbreviations

- 3GPP - Third generation partnership project
- AAA - Authentication, authorization and accounting
- AC - Authentication center
- AMPS - Advanced mobile phone service
- ANSI - American National Standards Institute
- ATM - Asynchronous transfer mode
- BSC - Base station controller
- BSS - Base station subsystem
- BTS - Base transceiver station
- CDMA - Code division multiple access
- CN - Core network
- CSCF - Call state control function
- CRNC - Controlling part of RNC
- DECT - Digital Enhanced Cordless Telephone system
- DRNC - Drift RNC
- EGPRS - Enhanced GPRS
- EIR - Equipment identification register
- E-SGSN - Enhanced SGSN
- E-GGSN - Enhanced GGSN
- E-VMSC - Enhanced visited MSC
- E-MPSN - Enhanced mobile packet service node

Abbreviations

- FDD - Frequency division duplex
- GERAN- GPRS radio access network
- GGSN - Gateway GPRS support node
- GMSC - Gateway MSC
- GPRS - General packet radio service
- GSM - Global system for mobile communication
- HLR - Home location register
- HSCSD- High-speed circuit switched data service
- IP - Internet protocol
- IWF - Interworking function
- IWMSC- Interworking MSC
- MAP - Mobile application part
- MGW - Media gateway
- MGCF - Media gateway control function
- MPLS - Multi protocol label switching
- MS - Mobile subscriber
- MT - Mobile terminal
- PDC - Personal digital cellular system
- PDSN - Packet data service node
- PHS - Personal handyphone system

Abbreviations

- RAN - Radio access network
- RNC - Radio network controller
- RNS - Radio network subsystem
- SCP - Service control point
- SGSN - Serving GPRS support node
- SIP - Session initiation protocol
- SMS - Short message service
- SRNC - Serving RNC
- STM - Synchronous transfer mode
- TDD - Time division duplex
- TDMA - Time division multiple access
- TE - Terminal equipment
- UE - User equipment
- UMTS - Universal mobile telecommunication system
- UTRAN-UMTS terrestrial radio access
- UWC - Universal wireless communication system
- VLR - Visitor location register
- WAP - Wireless application protocol
- WCDMA-Wideband CDMA